



Features :

- Universal AC input: 90-305VAC
- Built-in active PFC Function: >0.92
- Protections: SCP/OCV/OVP/OTP
- IP67/IP65 sealing design for outdoor or indoor installations, and cooling by free air convection
- Built-in constant current limiting circuit (CV+CC model), output current/voltage adjustable
- Optional for 1~10Vdc, resistor or PWM signal 3 in 1 dimming function
- Suitable for LED lighting, Street lighting, Display applications
- Suitable for wet/damp/dry/cold temperature/high temperature locations
- High efficiency up to 91%
- 6000V lighting surge protection
- High reliability: Adopt RAGU patent potting technology for glue stress release
- Compliance to UL60950-1, IEC60950& UL8750 safety regulations
- 5 years warranty (Note .9)



RG75-W1C XXX SH X: Note : X can be A,T ,B , the output current is XXX/100  
 A: IP65 rated , Output current and voltage level can be adjustable through internal potentiometer .  
 T: IP67 rated , Output current level adjustable through output cable with 1-10Vdc or PWM signal or resistance.  
 B: IP67 rated, Without dimming or adjustable function , connected with input/output cable .

■ SPECIFICATION

MODEL		RG75-W1C320SHX	RG75-W1C200SHX	RG75- W1C160SHX
OUTPUT	DC VOLTAGE	24V	36V	48V
	RATED CURRENT	3.2A	2.0A	1.6A
	VOLT RANGE AT CC OUTPUT	14.4~24V	21.6~36V	28.8~48V
	RATED POWER	75W	75W	75W
	RIPPLE&NOISE Note.2	150mvP-P	200mvP-P	300mvP-P
	VOLTAGE RANGE Note.5	22~27V	33~40V	43~53V
	CURRENT ADJ RANGE	Can be adjusted by internal potentiometer , A type only		
		1.9~3.2A	1.2~2.0A	1.0~1.6A
	VOLTAGE TOLERANCE Note.3	±1%		
	LINE REGULATION	±0.5%		
	LOAD REGULATION	±0.5%		
	SETUP,RISETIME Note.7	2500ms 80ms (at full load) 230VAC/115VAC		
HOLD UP TIME (typ.)	16ms (at full load) 230VAC/115VAC			
EFFICIENCY (Typ.)	89.0%	90.0%	91.0%	
INPUT	VOLTAGE RANGE Note.4	90~305VAC		
	FREQUENCY RANGE	47~63Hz		
	POWER FACTOR(Typ.)	PF>0.98/115VAC PF>0.95/230VAC PF>0.92/277VAC(at full load)		
	AC CURRENT (Typ.)	0.84A/115VAC 0.42A/230VAC 0.3A/277VAC		
	INRUSH CURRENT (Type.)	Cold start 60A(twidth=425us at 50% Ipeak)/230VAC		
LEAKAGE CURRENT	<0.75mA/277VAC			
PROTECTION	OVER CURRENT	95~108%		
	SHORT CIRCUIT	Protection type: constant current limiting , recovers automatically after fault condition is removed		
	OVER VOLTAGE	28~34V	41~46V	54~60V
		Protection type : Shut down o/p voltage with auto-recovery or re-power on to recovery		
	OVER TEMP	100°C ±10°C		
	Protection type: shut down output , recovers automatically after temperature goes down to definite level			

ENVIRO MENT	WORK TEMP	-40℃ ~ 70℃ (Refer to "derating curve")
	WORK HUMIDITY	5 ~ 95%RH non-condensing
	STORAGE TEMP., HUMIDIT	-40 ~ +80℃, 10 ~ 95%RH
	TEMP. COEFFICIENT	±0.03%/℃ (0 ~ 50℃)
	VIBRATION	10-500Hz, 5G 12 min./1 cycle, period for 72min. each along X, Y, Z axes
SAFETY & EMC	SAFETY STANDAR Note.6	CE/CB Standard : EN/IEC61347-1 EN/IEC61347-2-13 UL Standard: UL8750 & UL1012 design refer to UL60950 UL60950 IEC60950 GB4943
	WITHSTAND VOLTAGE	I/P-O/P: 3KVAC I/P-FG: 2KVAC O/P-FG: 0.5KAC
	ISOLATION RESISTANCE	I/P-O/P, I/P-FG, O/P-FG 100MΩ/500VDC/25℃/70%RH
	EMC EMISSION	EN55015, EN55022 (CISPR22) Class B CE/EMC Standard: EN55015, EN61000-3-2/3 ; FCC Standard: FCC Part
	EMC IMMUNITY	EN61000-4-2, 3, 4, 5, 6, 8, 11 EN61547 EN55024 (Surge 6KV)
OTHERS	MTBF	≥250Khrs MIL-HDBK-217F(25℃)
	DIMENSION	171*61.5*37.0mm (L*W*H)
	PACKING	0.70kg; 12pcs/8.4kg/0.74CUFT
NOTE	<ol style="list-style-type: none"> <li>All parameters NOT specially mentioned are measured at 230VAC input, rated load and 25℃ ambient temperature.</li> <li>Ripple &amp; Noise are measured at 20MHz of bandwidth by using a 12" twisted pair-wire terminated with a 0.1μf &amp; 47μf parallel capacitor.</li> <li>Tolerance: includes set up tolerance, line regulation and load regulation.</li> <li>Derating may be needed under low input voltages. Please check the static characteristics for more details.</li> <li>Only A type</li> <li>Safety and EMC design refer to EN60598-1, subject 8750(UL), CNS15233, GB7000.1, FCC part 18.</li> <li>Length of set up time is measured at cold first start, Turning ON/OFF the power supply may lead to increase of the set up time</li> <li>The power supply is considered as a component that will be operated in combination with final equipment, Since EMC performance will be affected by the complete installation, the final equipment manufacturers must re-qualify EMC Directive on the complete installation again</li> <li>Refer to warranty statement.</li> </ol>	

## Mechanical Specification

### ● RG75 A-type

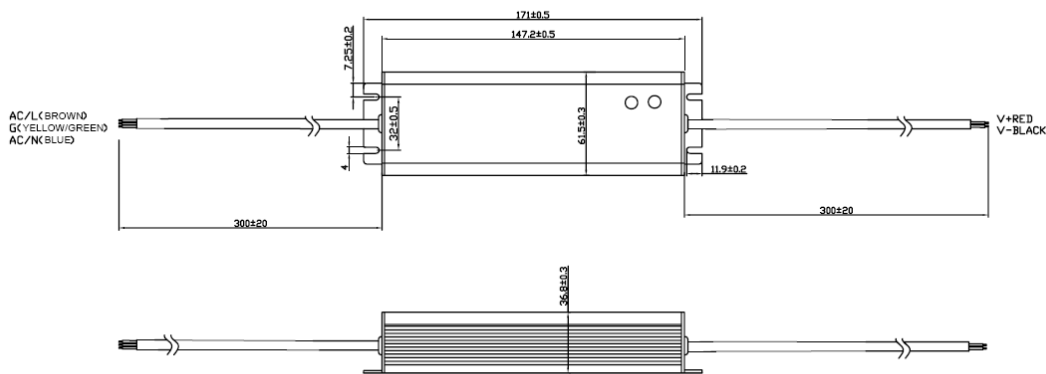

### ● RG75 T-type

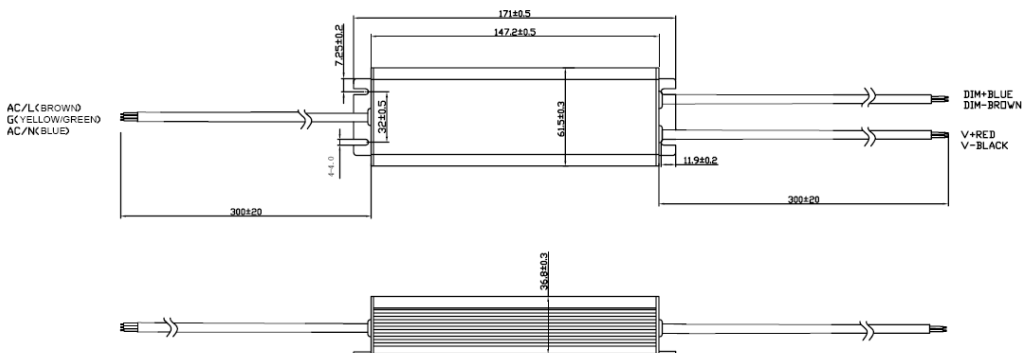

● RG75 B-type

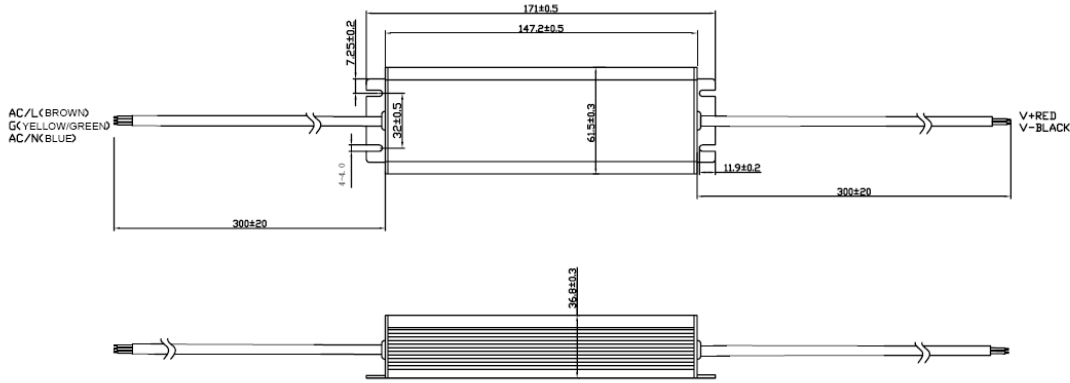

■ DRIVING METHODES OF LED MODULE

There are two major kinds of LED driver method "Directive drive" and "with LED driver"

A typical LED power supply may either work in "constant voltage model (CV) or constant current model (CC)" to drive the LEDs .

RAGU's LED power supply with CV+CC characteristic can be operated at both CV mode ( with LED driver , at area(A) and CC mode(direct driver at area (B) .

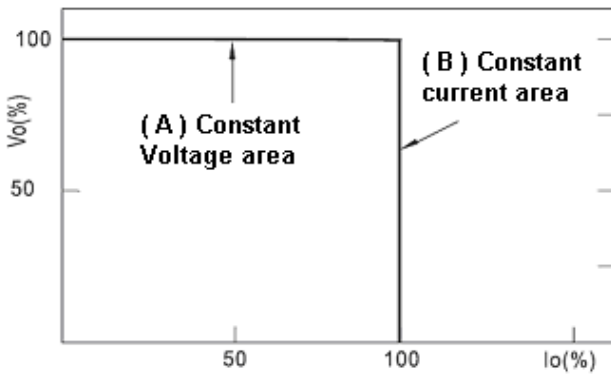

Typical LED power supply I-V curve

■ Power Factor Characteristic

Constant Current Mode

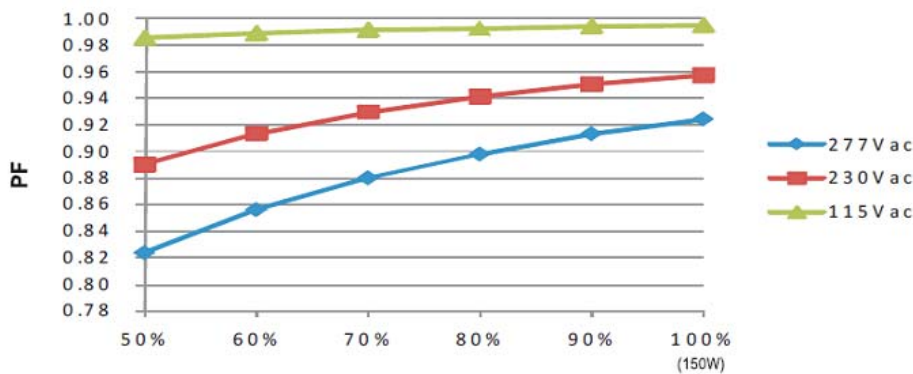

EFFICIENCY VS LOAD (48V model)

RG75 Series possess superior working efficiency that up to 94% can be reached in field applications .

Efficiency(%)

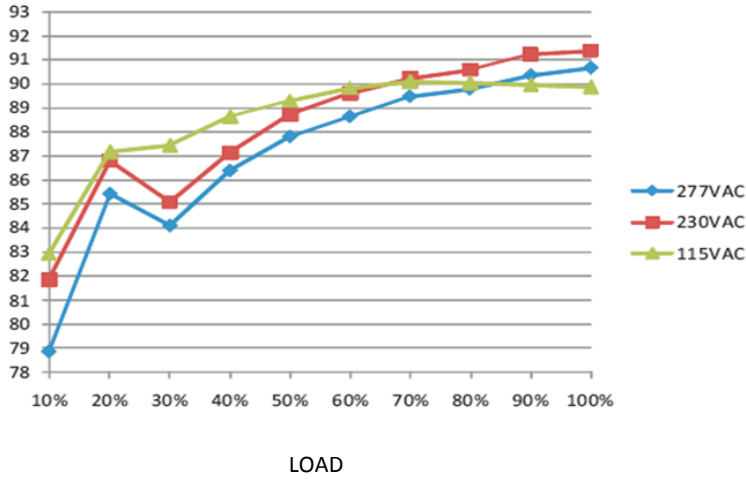

DERATING CURV

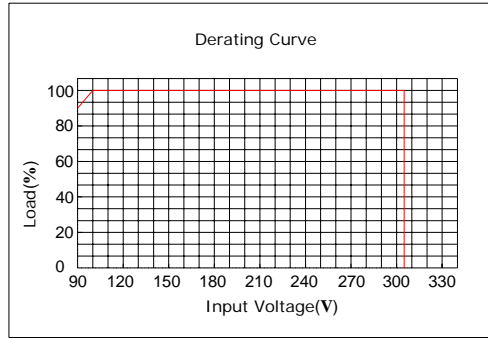
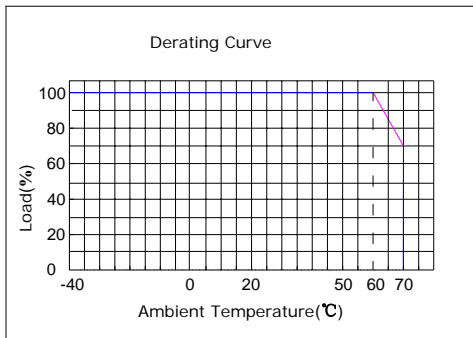

DIMMING OPERATION (for T-type only)

- ✧ Built-in 3 in 1 dimming function , IP67 rated . Output constant current level can be adjusted through output cable by connecting a resistor or 1-10Vdc or 10V PWM signal between DIM+ and DIM-
- ✧ Please DO NOT connect "DIM-" to "-V" .

Refer to resistance value for output current adjustment (Typical) .

resistance value (KΩ)	10	20	30	40	50	60	70	80	90	100	OPEN
Percentage of rated current (%)	10	20	30	40	50	60	70	80	90	100	95~108

1~10V dimming function for output current adjustment (Typical)

Dimming value( V )	1	2	3	4	5	6	7	8	9	10	OPEN
Percentage of rated current (%)	10	20	30	40	50	60	70	80	90	100	95~108

10V PWM signal for output current adjustable (Typical) : Frequency range 100Hz~3KHz

Duty value(%)	10	20	30	40	50	60	70	80	90	100	OPEN
Percentage of rated current (%)	10	20	30	40	50	60	70	80	90	100	95~108

- ✧ Using the built-in dimming function on T-type model can't turn the lighting fixture totally dark . Please refer to the connection method below to achieve 0% brightness of the lighting fixture connection to the LED power supply unit .
- ✧ Direct connecting to LEDs is suggested , but is not suitable for using additional drivers .

Dimming connection diagram for turning the lighting fixture ON/OFF :

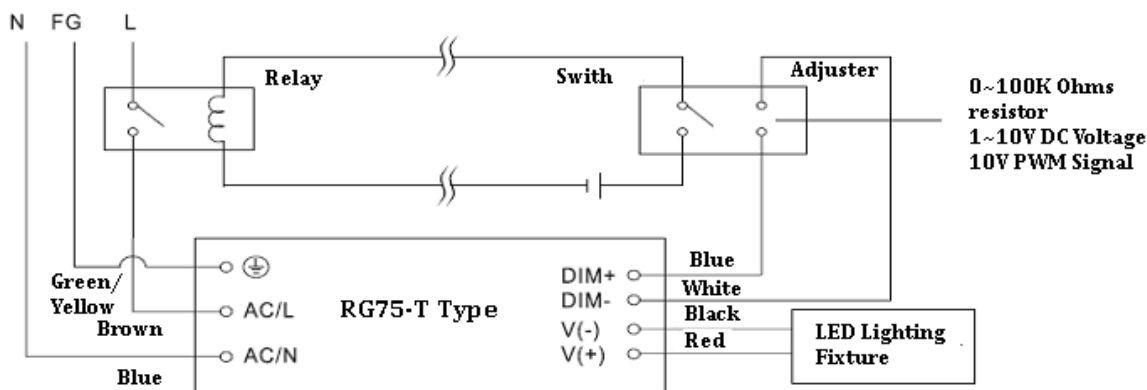

Using a switch and relay can turn ON/OFF the lighting fixture

1. Output constant current level can be adjusted through output cable by connecting a resistor or 1-10Vdc or PWM signal between DIM+ and DIM-
2. The LED lighting fixture can be turned ON/OFF by the switch .